

LOW EMI SPREAD SPECTRUM

EMC 60

Clock Oscillator

 **RoHS** 5.0VDC OR 3.3VDC, SMT

PRODUCT DESCRIPTION

The EMC60 Clock Oscillator is an advanced spectrum spread modulator with a standard TTL or CMOS compatible output that meets clock requirements of all major CISC, RISC, and DSP processors. It modulates clock harmonics to reduce electromagnetic emissions and associated harmonics at the source. The EMC60 is a direct replacement for 5V crystal oscillators and is plug compatible to standard Plastic. Surface Mount packages. It is available in a wide range of Selectable Output Frequencies (6 to 120 MHz).

The EMC60 can reduce emissions up to 20 dB. Compliance with international regulations can be obtained with EMC60 during pre-production and compliance testing, effectively eliminating multiple design and testing cycles.

- Accelerate compliance approvals
- Reduce engineering and compliance costs
- Accelerate market launch schedules

OUTPUT DATA

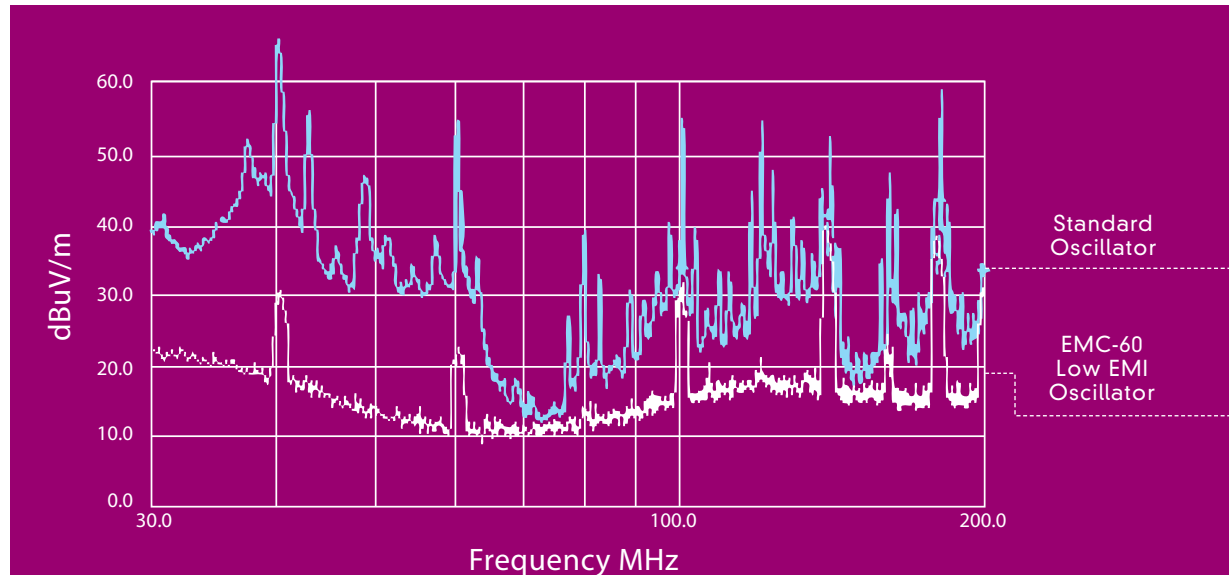

STANDARD OSCILLATOR COMPARED TO LOW EMI OSCILLATOR

APPLICATION

The EMC60 Clock Oscillator is designed for installations into electronic equipment required to meet FCC or European EMC Directives and is particularly appropriate for applications in —

- Telecommunications
- Capital Equipment
- Consumer Electronics, Printers
- Aerospace
- Medical Equipment

Equipment previously classified as non-complying can be retrofitted at the compliance test lab or in the field with the EMC60S5 Clock Oscillator. Once upgraded, this same equipment can be shipped into any country requiring compliance.

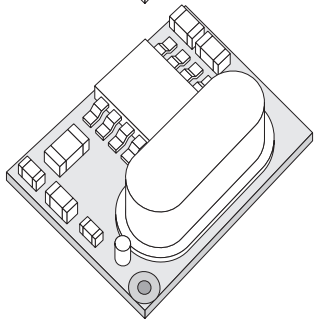
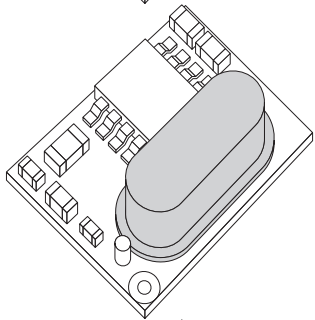
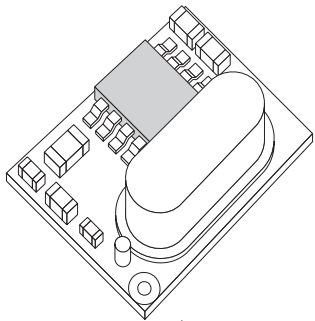

DIMENSIONS

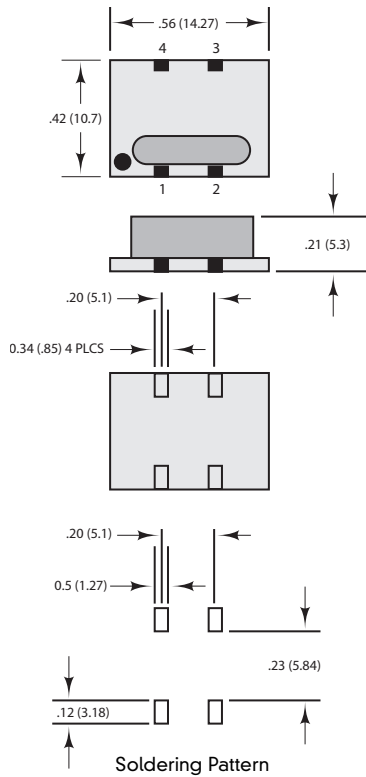

PIN CONFIGURATION

Pin Number	Function
1	NC
2	GND
3	OUTPUT
4	VDC

This device contains circuitry to protect the inputs against damage due to high static voltages or electric field; however, precautions should be taken to avoid application of any voltage higher than the maximum rated voltages to this circuit. For proper operation, V_{in} and V_{out} should be constrained to the range: $V_{SS} < (V_{in} \text{ or } V_{out}) < V_{DD}$. All inputs are tied high or low internally.

ORDERING OPTIONS

PRODUCT MODEL NUMBER + OPERATING VOLTAGE + OPERATING TEMPERATURE - FREQUENCY - LF - PACKAGING

EMC60

S3 for 3.3VDC
S5 for 5.0VDC

B = 0°C to +70°F

-020.000 for 20 MHz
-032.768 for 32.768 MHz
-128.000 for 128 MHz

Lead Free

-T = Tape and Reel (for 1,000 units or more)

EXAMPLE: EMC60S3B-033.000-T
For 3.3V Operating Voltage, 0° C to +70° C, 33.000 MHz with Tape and Reel

ABSOLUTE MAXIMUM RATINGS

Item	Symbol	Min	Max	Units
Operating Voltage	VDD	3.0	6.0	VDC
Input, relative to VSS	VIRvss	-0.3	VDD+0.3	VDC
Output, relative to VSS	VORvss	-0.3	VDD+0.3	VDC
AVDD relative to DVDD	ΔV_{pp}	-100	+100	mV
AVSS relative to DVSS	ΔV_{ss}	-100	+100	mV
Temperature, Operating	TOP	0	+70	°C
Temperature, Storage	TST	-65	+150	°C

ELECTRICAL CHARACTERISTICS

Characteristic	Symbol	Min	Typ	Max	Units
Input Low Voltage	VIL	—	—	0.3 VDD	VDC
Input High Voltage	VIH	0.7 VDD	—	—	VDC
Input Low Current	IIL	—	—	100	μA
Input High Current	IIH	—	—	100	μA
Output Low Voltage IOL=10mA, VDD=5V	VOL	—	—	0.4	VDC
Output High Voltage IOL=10mA, VDD=5V	VOH	VDD-1.0	—	—	VDC
Output Low Voltage IOL=6mA, VDD=3.3V	VOL	—	—	0.4	VDC
Output High Voltage IOL=5mA, VDD=3.3V	VOH	VDD-1.0	—	—	VDC
Short Circuit Current (FSOUT)	ISC	—	25	—	mA
Bandwidth Variations			5%*		%

* Unit is set @ 5% total BW ($\pm 2.5\%$ of center frequency)

TIMING CHARACTERISTICS

Characteristic	Symbol	Min	Typ	Max	Units
Output Rise Time Measured at 10%-90% @ 5VDC	tTLH	2	2.2	2.5	ns
Output Fall Time Measured at 10%-90% @ 5VDC	tTHL	1.7	2	2.2	ns
Output Rise Time Measured at 0.8V-2.0V @ 5VDC	tTLH	0.5	0.65	0.75	ns
Output Fall Time Measured at 0.8V-2.0V @ 5VDC	tTHL	0.5	0.65	0.75	ns
Output Rise Time Measured at 10%-90% @ 3.3VDC	tTLH	2.6	2.65	2.9	ns
Output Fall Time Measured at 10%-90% @ 3.3VDC	tTHL	2	2.1	2.2	ns
Output Rise Time Measured at 0.8V-2.0V @ 3.3VDC	tTLH	0.8	0.95	1.1	ns
Output Fall Time Measured at 0.8V-2.0V @ 3.3VDC	tTHL	0.78	0.85	0.9	ns
Output Duty Cycle	TsymF1	45	50	55	%

Measurements performed at VDD=3.3 and 5.0V $\pm 10\%$, Ta= 0°C to 70°C, CL=15pF, Xin+48 MHz